

# DOORS

HEAVY DUTY ROLL-UP



## 3100 SERIES

DBCI's 3100 Series is our certified windload rated, rolling sheet door that meets specified wind loads required by building codes. Independent laboratory testing proves the strength and durability of the 3100 series. The quick installation and smooth operation, compared to other doors, further demonstrates how user friendly this door is.

12"  
DRUM

WARRANTY  
40/35  
FILM/CHALK-FADE



The 3100 Series is wind load rated.  
The pressure rating increases as the door width decreases.

# 3100 SERIES

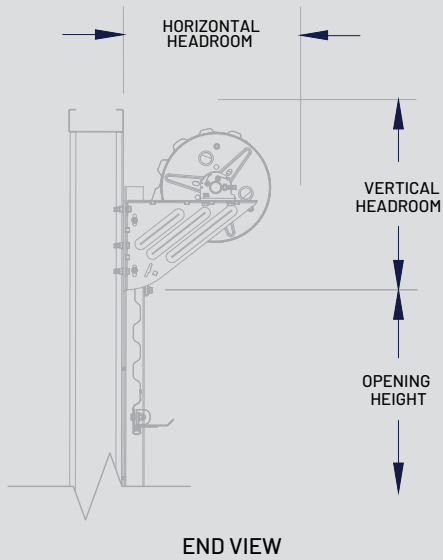

## IMPORTANT NOTES:

- Dimensions are referenced from edge of opening.
- Tensioner end and drive end can be installed at either end of door assembly.
- FOR CRITICAL FITS DUE TO REDUCED AVAILABLE HEADROOM or SIDEROOM CLEARANCES, CONSULT FACTORY.

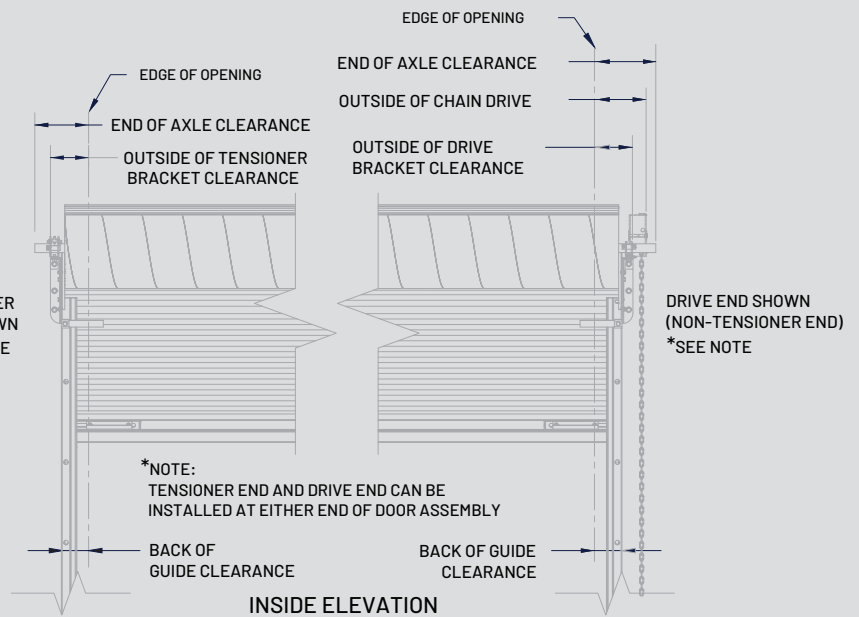

Universal mount 4" deep 12-gauge galvanized steel wind bar guides require no pre-installation modifications for steel, concrete or filled masonry block applications.

## SPECIFICATIONS

### Guide Details: Steel, Wood, Masonry, & Concrete Jamb

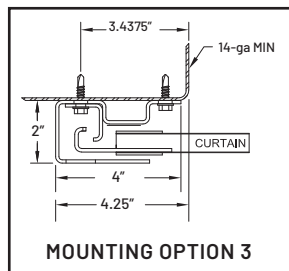
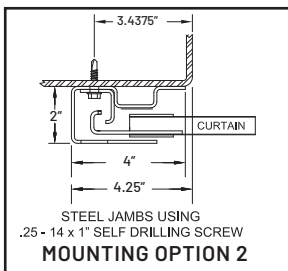
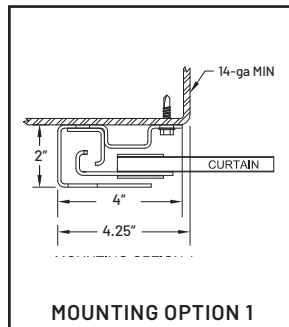
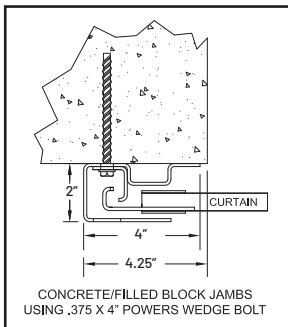

### Head Room Requirements

Opening Height	Vertical Headroom	Horizontal Headroom
Thru 8'0"	19"	20"
Thru 10'0"	21"	21"
Thru 14'0"	23"	23"
Thru 16'0"	24"	24"
Thru 18'0"	25"	25"
Thru 20'0"	26"	26"

### Side Room Requirements

Operation	Guide	Outside of Bracket Tensioner End	Outside of Hand Chain Drive	Outside of Bracket Drive End	Each End of Axle
Push Up	4-1/2"	6-1/4"	N/A	6-1/4"	10-1/2"
Reduced Drive Chain	4-1/4"	6-1/4"	8-3/4"	10"	10-1/2"
Electric	4-1/4"	6-1/4"	N/A	10"	10-1/2"

### HIGHLIGHTS:

- B** Barrel: 12"
  - G** Guide: 4", 12-gauge
  - 8:1 reduced-drive chain hoist offers smoother operation on doors over 10' tall.
- Visit [DBCI.com](http://DBCI.com) for technical drawings, color options and more.



The 3100 Series is wind load rated. The pressure rating increases as the door width decreases.



800-542-0501 • [info@dbci.com](mailto:info@dbci.com) • [www.dbci.com](http://www.dbci.com)