

**GENERAL NOTES:**

1. OPERATION TYPE MAY BE PUSH-UP, HAND CHAIN OR ELECTRIC.
2. FOR CRITICAL FITS DUE TO REDUCED AVAILABLE HEADROOM OR SIDEROOM CLEARANCES, CONSULT FACTORY.
3. CLEARANCES SHOWN ARE MAXIMUMS. LESSER CLEARANCES MAY BE POSSIBLE.
4. UNLESS OTHERWISE NOTED, DOORS SHALL BE PROVIDED WITH SLIDE LOCKS AT EACH END OF BOTTOM BAR, ENGAGING GUIDES IN THE LOCKED POSITION.
5. ALL OPENING PREPARATION, ELECTRICAL POWER AND FIELD PAINTING SHALL BE PROVIDED BY OTHERS.
6. SERIES 3100 IS AN INSULATED SERIES 3100
7. CURTAIN FINISH SHALL BE SILICONE POLYESTER PRE-PAINT OVER GALVANIZED GRADE 80 STEEL.
8. MODEL 3100 IS A STATE OF FLORIDA APPROVED WINDLOAD PRODUCT. PRODUCT EVALUATIONS AND STAMPED DRAWINGS ARE ACCESSIBLE VIA [www.floridabuilding.org](http://www.floridabuilding.org). FL#21450
9. MODEL 3100 IS EVALUATED FOR COMPLIANCE THROUGH TEXAS DEPARTMENT OF INSURANCE (TDI). PRODUCT EVALUATIONS AND STAMPED DRAWINGS ARE ACCESSIBLE VIA [www.tdi.texas.gov](http://www.tdi.texas.gov). TDI# GDR-41.
10. PLEASE NOTE: STANDARD GUIDE MANUFACTURING METHOD FOR STEEL JAMBS PER MOUNTING OPTION 1.
11. MAXIMUM OPEN SIZE: 20'-0" X 18'-0"

**BRACKET ATTACHMENT**  
 STEEL JAMBS: 3/8" - 16 X 1 1/4" HEX BOLT AND NUT.  
 CONCRETE/MASONRY JAMBS: 3/8" X 4" DEWALT WEDGE BOLT + SCREW ANCHORS  
 WOOD JAMBS: 3/8" X 3" LAG SCREW.

- (\*) FOR PUSH-UP OPERATION.....6 3/4"  
 FOR HAND CHAIN OPERATION.....6 3/4"  
 FOR ELECTRIC OPERATION.....7 3/4"  
 FOR OUTSIDE OF CHAIN DRIVE.....8 3/4"

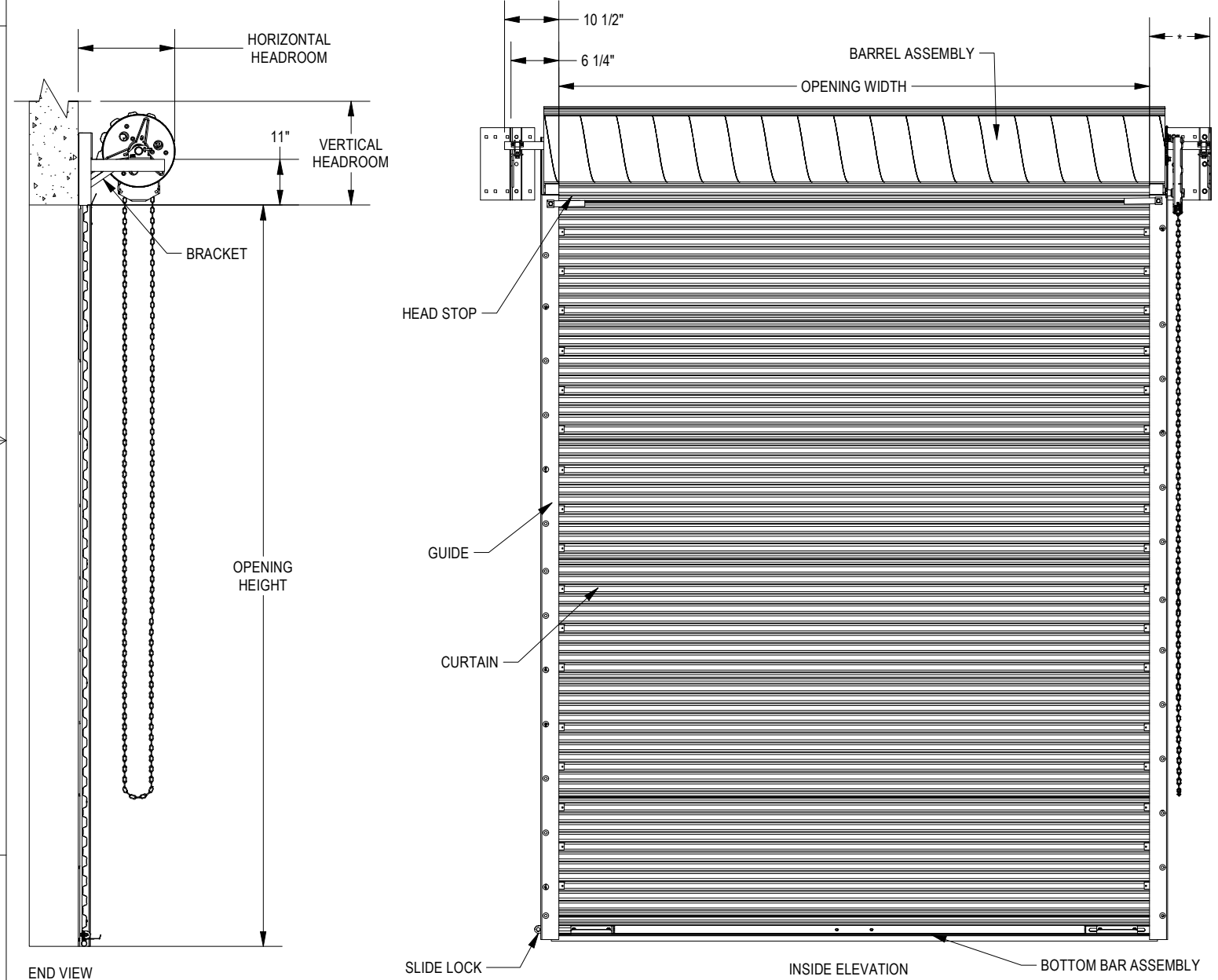
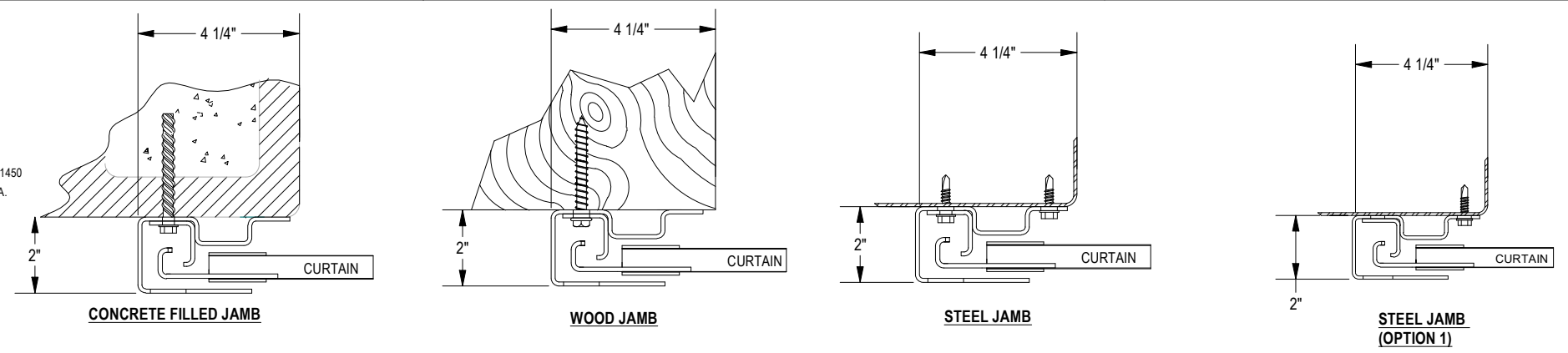

HEADROOM REQUIREMENT		
OPENING HEIGHT	VERTICAL HEADROOM	HORIZONTAL HEADROOM
THRU 8'-0"	19"	20"
THRU 10'-0"	21"	21"
THRU 14'-0"	23"	23"
THRU 16'-0"	24"	24"
THRU 18'-0"	25"	25"

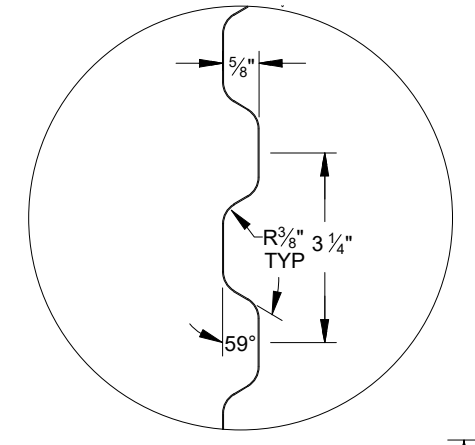

DETAIL A

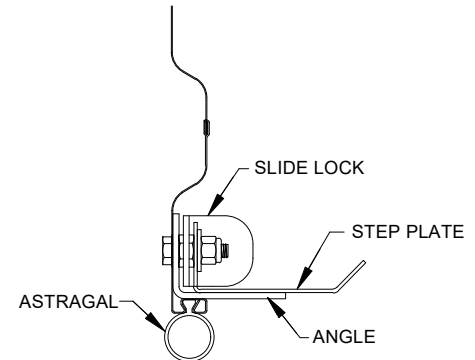
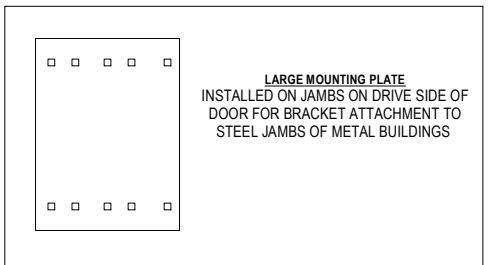

BOTTOM BAR ASSEMBLY

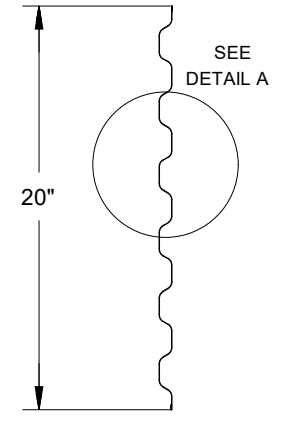

26 GA CURTAIN PANEL DETAIL

814005-0000 11/16/2022

## COMMERCIAL DOOR: 3100/3100I

CUSTOMER NUMBER:		DATE:	
CUSTOMER NAME:		CONTACT:	
PROJECT NAME:			
PROJECT LOCATION:			
PLANT:		SALESPERSON:	
DRAWN BY:		DRAWN BY DATE:	
DRAWING NUMBER:		SHT:	OF:

FACTORY ORDER NUMBER	DOOR SERIES	QTY	OPENING SIZE		JAMB TYPE			OUTSIDE CURTAIN COLOR	OPERATION			OPERATION HAND	WEATHERSTRIP			ADDED OPTIONS
			WIDTH	HEIGHT	STEEL	CONC./ MAS	WOOD		PUSH UP	REDUCED CHAIN	ELECTRIC		TOP	HEADER	SIDE	

NOTES:

