

DOORS

LIGHT DUTY ROLL-UP



650-NS SERIES

The **650-NS Series** from DBCI incorporates an enhanced design that includes anchored guides on the floor, ensuring both stability and durability. Ideal for light-duty use in carports, barns, sheds, and self-storage/commercial unit mix, Janus's industry leading roll-up doors are crafted for easy installation and minimal maintenance, providing a reliable solution for a variety of applications.

Pre-Lubricated Springs

During production, springs are factory lubricated and enclosed in a tube to protect them from the environmental elements.

Dead Axle & Barrel Assembly

An enclosed spiral barrel houses the dead axle assembly and offers durability and smoother operation as weight is distributed throughout the barrel.

Ratchet Tensioning Device

Allows you to simultaneously fine tune springs due to the eight different positions on the tension wheel, which provides equal pull on the left and right sides to ensure balanced operation of the door.

Enhanced Security

A robust lower bar, equipped with secure clips that smoothly glide within the guides, combine with firmly anchored guides on the floor to provide enhanced stability and support.

26-Gauge Corrugated Door Curtain

Manufactured from galvanized grade 80 steel and coated with super durable polyester paint in more than 30 color options.

Insulated Version Available

Side and top draft stops included.



SECURITY CLIPS installed in the bottom bar seamlessly ride within the guides.

Firmly anchored **SUPPORT ANGLES** are screwed into the floor for enhanced stability and support.



Maximum
10' x 10'

Available in sizes up to 10' x 10' and in more than 30 colors, customized for your application.



**Self-Storage/
Light-Duty**

Ideal for storage within carports, barns, sheds and self-storage/commercial unit mix.



**Enhanced
Security**

Featuring a reinforced bottom bar with secure clips that seamlessly ride inside the guides.



**Quality
Guaranteed**

Three-year door warranty.
For paint, 35-year no-fade,
40-year film integrity.

650-NS SERIES

LIGHT-DUTY ROLL-UP

All **DRUMS** are fitted with a grease filled, shielded radial ball bearing to contribute to a smoother operation and reduce wear and friction.

Factory installed galvanized reinforced 16-gauge **BRACKETS** (12-gauge for doors over 9' wide or 8' tall) are designed to easily bolt or snap onto the guides, reducing installation time.

Galvanized, guide-mounted **HEAD STOPS** are simple to install and prevent curtain over travel when raising the door. Installed through guide after curtain is lowered, they provide definite contact with the bottom bar angle and stop clips.

The **RATCHET SPRING TENSIONER ASSEMBLY** is factory installed on the tension end of the door assembly for easy tension/spring adjustment. Increments of 1/8" turn are possible. Tensioner adjusts both springs equally at the same time from only one end of the door.

Yellow zinc coated steel or optional stainless steel 4-bolt latch factory installed. The slide exhibits magnetic properties that can be used to activate a guide mounted security sensor. **LATCH** accepts all industry padlocks, including 7/16" diameter shanks. Provision for cylinder lock included.

Oil-tempered helical torsion **SPRINGS** are factory lubricated to minimize friction and corrosion while increasing the spring cycle life. Spring wire confirms to ASTM A 229.

Full width galvanized steel **BARREL** totally encloses the drums, springs and axle. Barrel-type construction reduces door sag, eliminates drum dents and improves operation due to an even support of the curtain for the entire width.

Galvanized and pre-painted with long lasting Super Durable polyester paint, the 26-gauge **CORRUGATED CURTAIN** is roll formed from ASTM A 653 grade 80 steel. This premium steel yields greater door strength and minimized curtain damage. Full height felt tape on inside of curtain prevents nesting and reduces paint rubbing. Available in sizes up to 10'0" x 10'0" and in over 30 different colors.

Roll formed, 18-gauge galvanized **GUIDES** are fitted with dual polyethylene wear strips to reduce friction and muffle door noises. All guide attachment to jamb is performed through the guides without the addition of clips welded to the back of the guide. This gives a neater appearance, increased strength and aids in tight installations.

Roll formed clear acrylic coated galvanized steel **BOTTOM BAR** reinforced with a 1-1/2" x 2" x 12-gauge full width galvanized angle that extends fully into the guides. The PVC bulb astragal provides positive contact with floor. Lift handle(s) installed on exterior side of bottom bar with interior stop clips and a non-rotting pull rope is attached to the inside angle.

Firmly anchored with 14-gauge **SUPPORT ANGLES** screwed into the floor for enhanced stability and support.

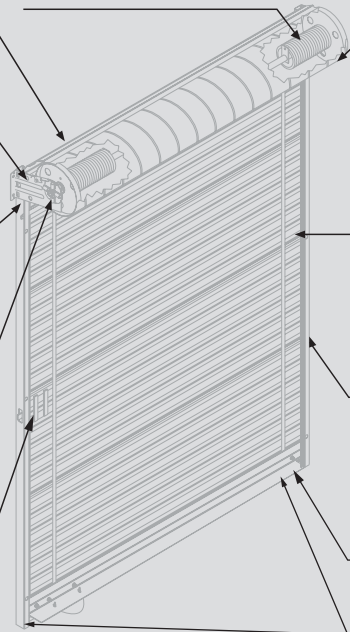

SPECIFICATIONS

Guide Details

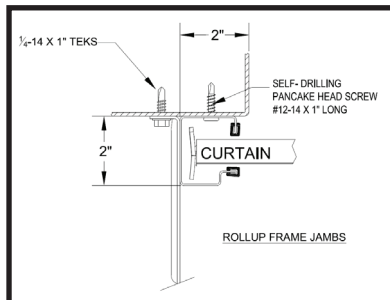

18-GAUGE GUIDE

Universal mount 2" deep, 18-gauge galvanized steel guides require no pre-installation modifications for wood, steel, concrete or filled masonry block applications.

Head Room Requirements

Opening Height	Vertical Headroom	Horizontal Headroom
Thru 7' ⁴ / ₄ "	15'-1/2"	17"
Over 7' ⁴ / ₄ " thru 8' ⁸ / ₈ "	16"	17'-1/2"
Over 8' ⁸ / ₈ " thru 10' ⁸ / ₈ "	17"	18'-1/2"

HIGHLIGHTS:

- B** Barrel: 9-1/2"
- G** Guide: 2", 18-gauge

Side Room Requirements

Operation	Outside of Bracket Tensioner End	Outside of Bracket Drive End (Non-Tensioner)
Push Up	3-1/2"	3-1/2"
Pantheon	3-1/2"	3-1/2"
ATA EZ Roller	3-1/2"	6-1/2"

